



**R. "LYNN" RUFFELL**

316 West Milwaukee Street; P.O. Box 511  
New Hampton, IA 50659  
P: 800-222-6047 x230 IC: 208-569-4061  
lynn@zips.com | www.zips.com



**TRAILMAX  
QUALITY,  
BACKED BY A  
5-YEAR  
STRUCTURAL  
WARRANTY**



- High Tensile Fabricated 4-beam Construction to Minimize Excess Frame Flex and Provide a More Safe and Stable Load
- Tubular Crossmembers on 12" Centers for Optimum Support of Concentrated Loads
- DOT Approved Sealed Beam, Rubber Isolated LED Lighting; Wiring Routed Through Tubular Construction to Protect from the Environment
- Shot Blasted Followed by a Phosphate Wash and Seal provides Clean Base of Paint Adhesion. Epoxy Primer and an Enamel Top coat for a Durable Finish
- 20,000# Capacity Hydraulic 2-stage Planetary Gear Winch for Easy Loading of Equipment
- 2500 PSI hydraulic system transitions trailer to a 6° load angle (available with self contained power unit or run off wet kit)
- Available in various configurations including
  - Fifthwheel or tag configuration
  - Length configuration
  - Tandem or triple axle configuration
  - Various capacities available
- Various options available including
  - Self contained power unit in lieu of wet kit
  - D-rings or belt winches to specification
  - Outriggers
  - Hubometer
  - Custom paint & detail

**"Setting the Industry Standard"**

*Maximum performance*

*Maximum reliability*

*Maximum return on investment*



**"For the Long Haul"**

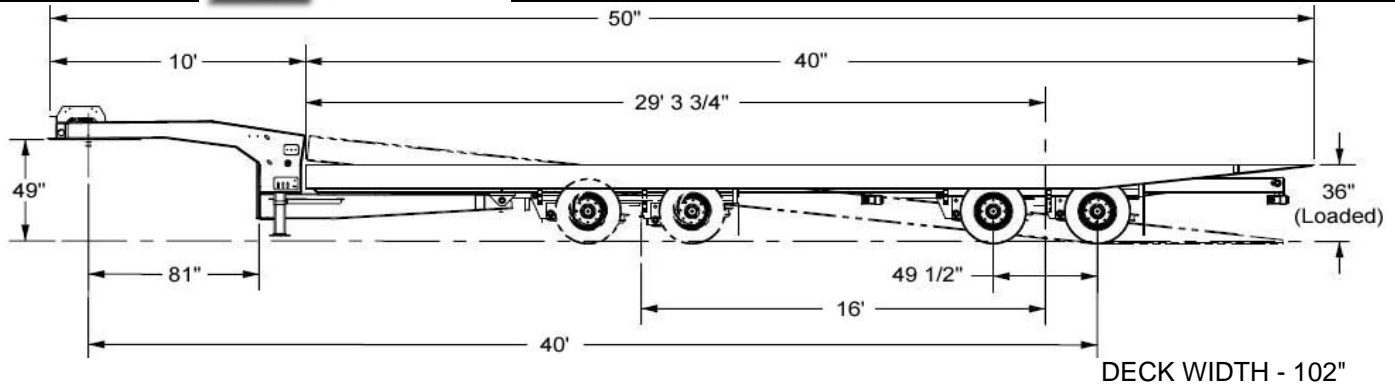

Capacity (Distributed)	70,000 lbs.
Concentrated Load	50,000 lbs. in 10'
Trailer Weight	17,580 lbs.
Frame Construction	Fabricated 4-beam design A-656 high tensile
Crossmembers	4" and 3" Tubular on 12" centers
Hitch	King Pin type 150,000 PSI ultimate strength, 115,000 yield
King Pin Setting	18"
Swing Clearance	81"
Loaded Deck Height	36"
Load Angle	6 degrees
Dump Angle	16 degrees
Deck Width	102"
Landing Gear	2 Speed 70,000 lb., 100,000 lb. static load
Load Securement	2-way Chain Slot/Stake Pocket design
Undercarriage	Hydraulically actuated 192" traveling axle system
Hydraulic System	2500 PSI 15 GPM 3-stack valve plumbed to quick disconnects
Tool Compartment	2 each in Fifth Wheel upper deck
Winch	20,000 lb. Hydraulic 2-stage Planetary Gear with recessed cable rollers
Axles	2 each 25,000 lb. capacity, 5 in. round 1/2" wall thickness, 71 1/2" track
Hubs	Oil bath type with Unimount Hub and drum, 8 on 275mm bolt circle
Brakes	12-1/4" x 7-1/2" s-cam full air brakes with maxi spring brakes on both axles, automatic slack adjusters, equipped with 2S 1M anti-lock braking system
Drums	Steel Outboard type
Suspension	Ridewell Model 240 Air Ride
Wheels	17.5" x 6.75" Uni-mount 8 on 275mm bolt circle
Tires	215/75R 17.5 radial load range H
Finish Preparation	5 stage pre-treatment
Base Coating	DuPont two-component epoxy primer sealer
Finish Coating	DuPont two-component urethane enamel top coat
Electrical	Trucklite modular system with rubber isolated, sealed beam LED lighting, protected in tube construction
Decking	1 3/8" Apatong Hardwood
Various Options	Spare Tire, Spare Tire Carrier, Apatong Decking, Traction Devices, D-rings, Belt Winches, 48" Underbody Toolbox, Custom Paint & Detail

Specifications are subject to change without notice